



OIEODINAMICA **BORELLI**
HYDRAULIC COMPONENTS

- TAVOLA RICAMBI MOLTIPLICATORE Gr. 3,5
- TABLEAU DES PIÈCES DÉTACHÉES DU MOLTIPLICATEUR GR. 3,5
- SPARE PARTS TABLE OVER-GEAR GR. 3,5
- ERSATZTEILLISTE ÜBERSETZUNGSGETRIEBE Gr. 3,5

SERIE: 80000

ARTICOLI FUORI PRODUZIONE

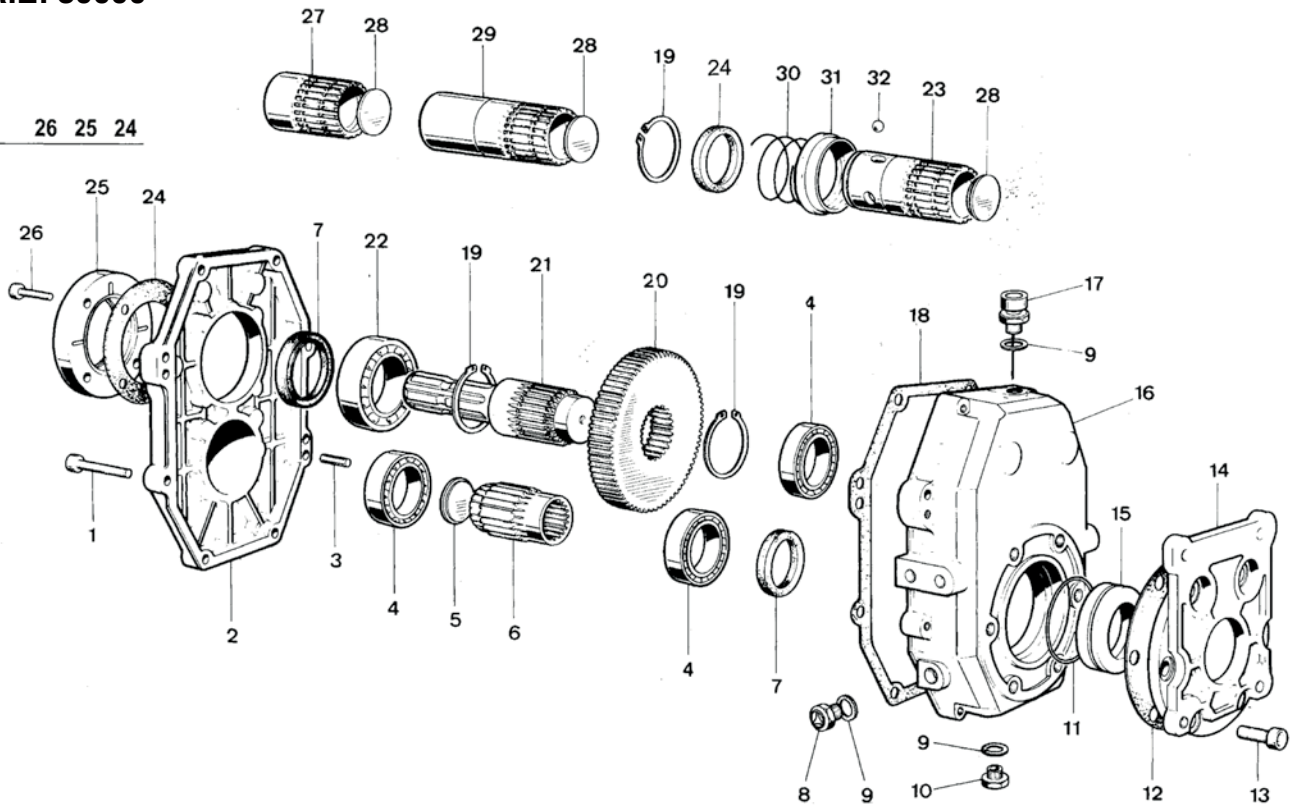

POS.	DENOMINAZIONE	DENOMINATION	DESCRIPTION	BEZEICHNUNG	Q.TÀ
1	Vite T.C.E.I. M8x40	Vis T.C.H.C. M8x40	Socket capscrew M8x40	Zylinderkopfs. m. Innensechsk. M8x40	8
2	Coperchio	Couvercle	Cover	Dekel	1
3	Spina 8x30	Goupille 8x30	Peg 8x30	Stift 8x30	2
4	Cuscinetto tipo 6010	Palier 6010	Bearing type 6010	Kugellager, Type 6010	3
5	Coperchietto DIN 470	Petit couvercle DIN 470	Cap DIN 470	Deckel DIN 470	1
6	Pignone	Pignon	Pinion Gear	Ritzel	1
7	Anello di tenuta Ø 50x65x8	Bague d'étanchéité 50x65x8	Sealing ring Ø 50x65x8	Dichtring, Durchm. 50x65x8	2
8	Tappo	Bouchon	Plug	Schraube	1
9	Guarnizione	Joint	Gasket	Dichtung	3
10	Tappo scarico olio	Bouchon vidange huile	Oil drain plug	Ölablaßschraube	1
11	Anello OR	Bague torique	O-Ring	O-Ring	1
12	Guarnizione	Joint	Gasket	Dichtung	1
13	Vite T.C.E.I. M12x20	Vis T.C.H.C. M12x20	Socket capscrew M12x20	Zylinderkopfs. m. Innensechskant M12x20	6
14	Flangia	Bride	Flange	Flansch	1
15	Anello porta corteco	Bague porte-bague corteco	Corteco Ring	Corteco-Ring	1
16	Scatola	Carcasse	Housing	Gehäuse	1
17	Asta sfiato e livello olio	Jauge de reniflard et niveau d'huile	Oil dipstick with vent	Entlüftungs und Ölmesstab	1
18	Guarnizione	Joint	Gasket	Dichtung	1
19	Anello seeger	Circlip	Snap ring	Seegerring	3
20	Corona	Couronne	Ring gear	Zahnkranz	1
21	Albero presa di forza maschio 1 3/8"	Arbre prise de force mâle 1" 3/8	Male P.T.O. shaft 1" 3/8	Antriebswelle mit Aussenverkeilung 1 3/8"	1
22	Cuscinetto tipo 6210	Palier 6210	Bearing type 6210	Kugellager, Type 6210	1
23	Albero presa di forza femmina 1 3/8"	Arbre prise de force femelle 1" 3/8	Female P.T.O. shaft 1" 3/8	Antriebswelle mit Innenverkeilung 1 3/8"	1
24	Guarnizione	Joint	Gasket	Dichtung	1
25	Coperchietto	Petit couvercle	Cap	Deckel	1
26	Vite T.C.E.I. M6x20	Vis T.C.H.C. M6x20	Socket capscrew M6x20	Zylinderkopfs. m. Innensechskant M6x20	4
27	Albero presa di forza femmina 1 3/8" corto	Arbre prise de force femelle 1" 3/8 court	Female P.T.O. shaft 1" 3/8 short	Antriebsw. m. Innenverkeilung 1 3/8", kurz	1
28	Coperchietto	Petit couvercle	Cap	Deckel	3
29	Albero presa di forza femmina 1 3/8" lungo	Arbre prise de force femelle 1" 3/8 long	Female P.T.O. shaft 1" 3/8 long	Antriebsw. m. Innenverkeilung 1 3/8", lang	1
30	Molla	Ressort	Spring	Feder	1
31	Anello porta molla	Bague porte-ressort	Spring ring	Federhaltering	1
32	Sfera	Bille	Ball	Kugel	3
33	Anello	Bague	Ring	Ring	1



SERIE: 80000

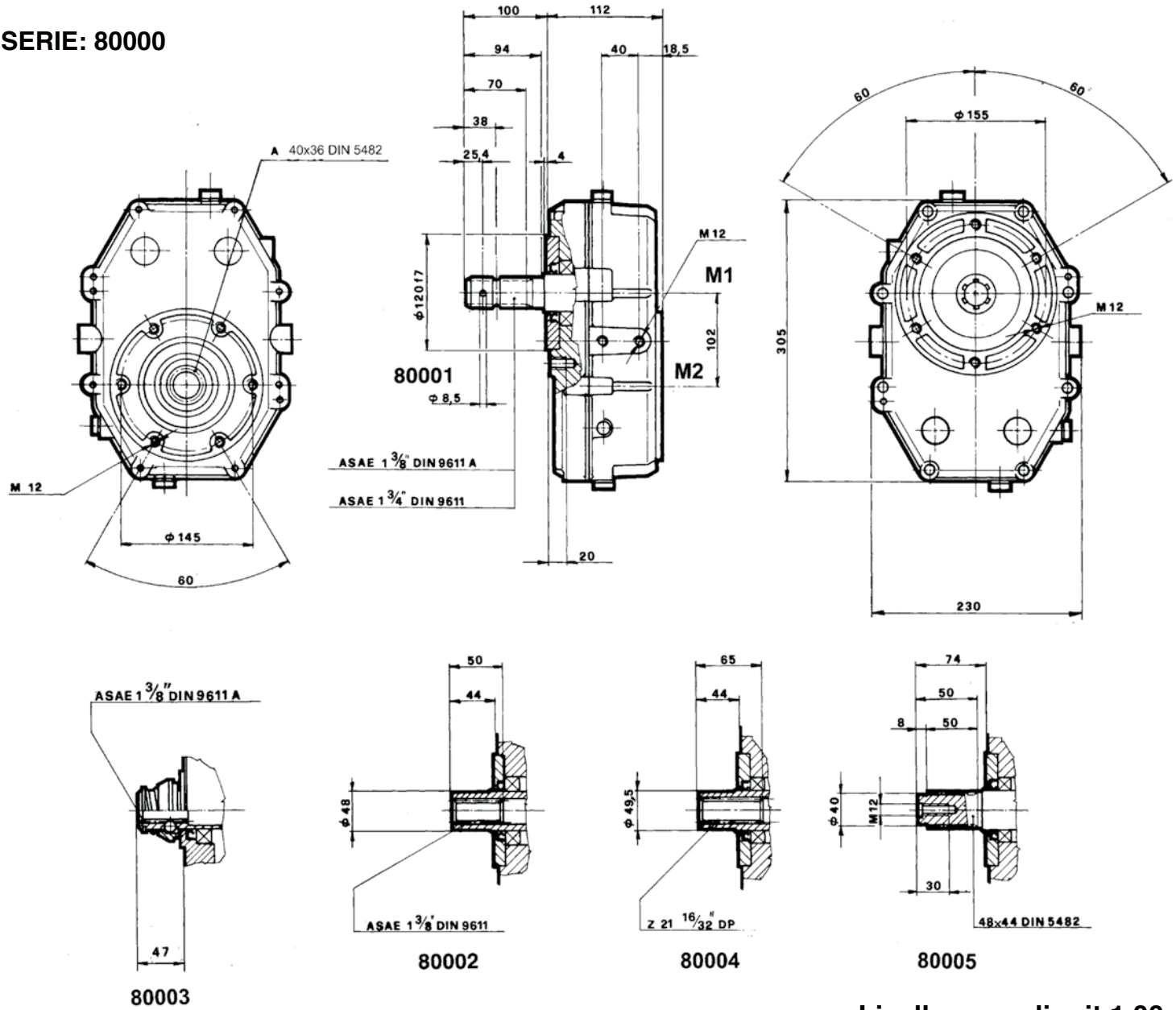

Livello max olio: it 1,00

M1 da Nm	M2 da Nm	N. 1 giri/1' tours/1' R.P.M U/min	N. 2 giri/1' tours/1' R.P.M U/min	I N.1/N.2	POTENZA Kw	G Kg
46,6	46,6	540	540	1	36	13,5
48	32	540	810	1,5	36	13,5
48,4	24,2	540	1080	2	36	13,5
46,8	18	540	1408	2,5	36	13,5
48,9	16,3	540	1620	3	36	13,5
45,9	13,5	540	1836	3,5	36	13,5
47,5	12	540	2052	3,8	36	13,5
47,2	11,8	540	2160	4	36	13,5
47	9,8	540	2592	4,8	36	13,5