

REGOLATORE DI FLUSSO PRIORITARIO FLANGIABILE PER MOTORI DANFOSS OMS

FLOW CONTROL VALVE EXCESS TO TANK FLANGEABLE ON DANFOSS MOTORS OMS

TIPO / TYPE
RFP3 OMS

SCHEMA IDRAULICO
HYDRAULIC DIAGRAM

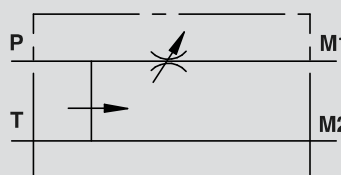

IMPIEGO:

Valvola che consente di mantenere costante la portata in P ad un valore stabilito, indipendentemente dalla pressione richiesta e dalla portata in entrata alla valvola. La portata in eccesso viene mandata direttamente sulla linea di ritorno (T).

La flangiatura diretta, adatta per motori Danfoss della serie OMS, garantisce la massima sicurezza, minime perdite di carico e compattezza d'installazione.

MATERIALI E CARATTERISTICHE:

Corpo: acciaio zincato.

Componenti interni: acciaio temprato termicamente e rettificato.

Guarnizioni: BUNA N standard.

Tenuta: per accoppiamento. Trafilamento minimo (poche gocce al minuto).

MONTAGGIO:

Flangiare M1 e M2 al motore, collegare le bocche P e T all'alimentazione.

A RICHIESTA:

Pomolo a tenuta (CODICE/P).

DIAGRAMMA COMPENSAZIONE

COMPENSATION CURVE

USE AND OPERATION:

This valve enables to keep the flow to P constant to a required setting, independent of pressure or inlet flow. Excess flow is drained to T (tank).

Direct flange mounting for Danfoss motors type OMS provides maximum safety, very low pressure drop and a robust installation.

MATERIALS AND FEATURES:

Body: zinc-plated steel.

Internal parts: hardened and ground steel.

Seal: BUNA N standard.

Load holding : matched diameters, minimal leakage (few drops per minute).

CONNECTIONS:

Connect M1 and M2 to the motor and P and T to the supply.

ON REQUEST:

Water proof adjustment knob (CODICE/P).

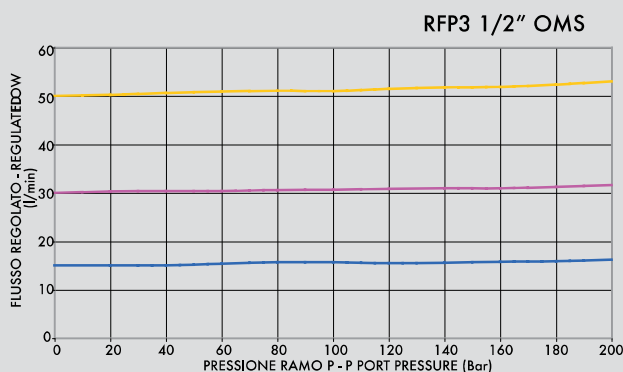



CODICE CODE	SIGLA TYPE	PORTATA MAX ENTRANTE MAX INLET FLOW Lt. / min	PORTATA MAX REGOLATA MAX ADJUSTED FLOW Lt. / min	PRESSIONE MAX MAX PRESSURE Bar
V1122	RFP3 1/2" OMS	60	50	350

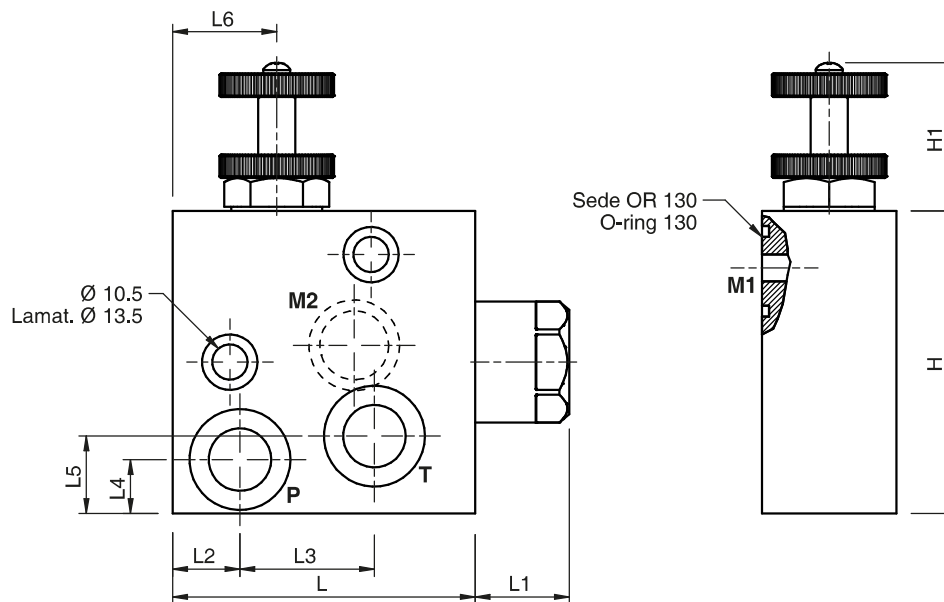

CODICE CODE	SIGLA TYPE	P. T GAS	L mm	L1 mm	L2 mm	L3 mm	L4 mm	L5 mm	L6 mm	H mm	H1 mm	S mm	PESO WEIGHT kg
V1122	RFP3 1/2" OMS	G1/2"	90	26	20	40	16	23	31	90	35	40	2,410