



## 4/2, 4/3 WAY DIRECTIONAL VALVES TYPE KV

- NG 16
- To 350 bar [5 076 PSI]
- To 300 L/min [79 GPM]

- Indirect, solenoid, and mechanical (by lever) operation.
- Connection diagram and connecting dimensions to ISO 4401.
- Plug-in solenoid connector to ISO 4400.
- Protection of solenoid IP 65 to EN 60529 / IEC 60529.
- Fulfil EMC (89/336/EEC).



KV-4/3-16-

### Operation

Directional valves type KV with indirect, solenoid-hydraulic operation control the hydraulic fluid flow direction.

These valves consist of the main valve (1), a control spool (2), two return springs (3) in 4/3-way valves and none in 4/2-way valves, a double throttle check/valve (4) and a pilot valve (5).

The pilot valve (5) is connected with the pressure chambers (8) via the pilot line (7). Feeding of the pilot valve oil is either external (via the port "x"). Change-over of the control spool to one of the operating position is activated by the introduction of oil via the pilot valve (5) into one of the pressure chambers (8). A pressure rise in chambers provokes the movement of the control spool (2). Suitable links between ports A,B,P,T according to spool types are established as set forth in the table.

When the solenoid of the pilot valve (5) are de-energized a link between the pressure chamber (8) and the return line "y" for the pilot oil discharge is established. A pressure drop in the chamber actuates the main valve return spring (3) which automatically return the control spool to the neutral position.

Discharge of the return pilot oil from the pressure chambers is either internal or external (via the port "y").

Manual change-over of the main valve is also possible by pressing the emergency hand operator (9).

Indirect directional valves can also be provided with a manual pilot valve. These valves are manually operated by moving the operating lever.

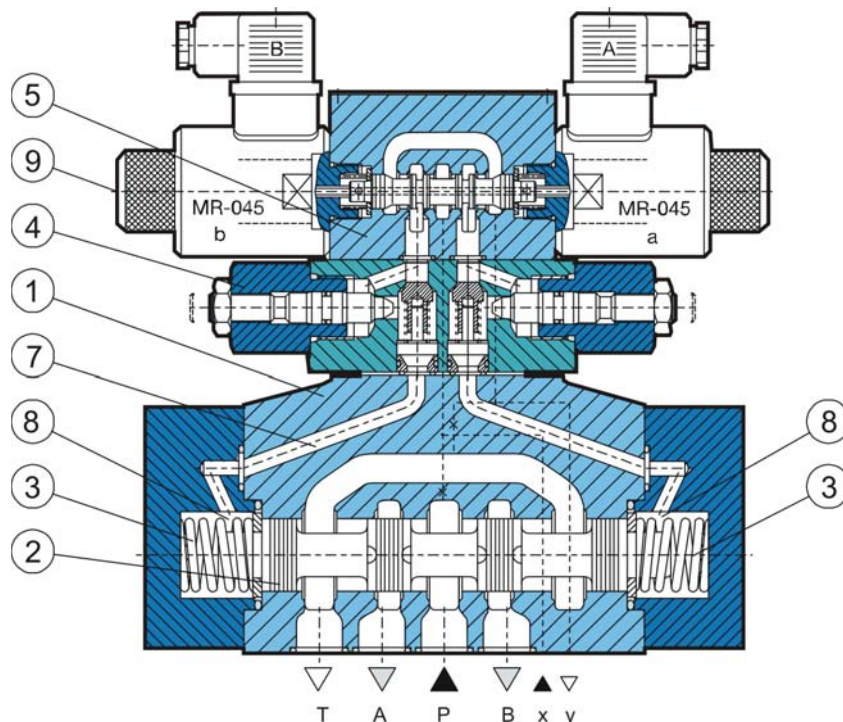

### Hydraulic symbols

Spool types

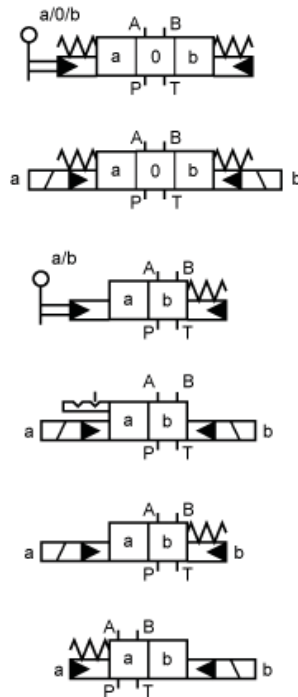

Mechanically operated

Hydraulically operated

Electrically operated

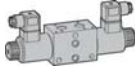

**Features**

<b>Flow rate</b>	l/min [GPM]	300 [79.2]	
<b>Operating pressure</b>	bar [PSI]	Ports A, B, P	350 [5076.3]
		Port T	250 [3625.9]
<b>Pilot oil pressure (x-external)</b>	bar [PSI]	50-250 [725.2-3625.9]	
<b>Pilot oil pressure (x-internal)</b> Pre-load valve is fitted into P-port of the main valve Without Pre-load valve in the P-port of the main valve		In valve types with internal pilot oil supply (x) the spool types 2, 3, and 4 are possible only when the oil flow in the direction from P towards T achieves the flow rate Q = 150 L/min [39.6 GPM], with the control spool in the centre position.	
<b>Oil temperature range</b>	°C [°F]	-20 to +70 [-4 to 158]	
<b>Viscosity range</b>	mm <sup>2</sup> /S	15 to 380	
<b>Required pilot oil volume</b>	cm <sup>3</sup> [cu.in]	2 positions valve	7,8 [0.47]
		3 positions valve	3,9 [0.24]
		Main valve	8 [17.6]
		4/3 pilot valve	2,5 [5.5]
		4/2 pilot valve	2,2 [4.8]
<b>Mass</b>	Kg [lb]	Throttle/check valve	1,45 [3.2]
		Pressure reducing valve	1,70 [3.7]
<b>Mounting position</b>		Optional, horizontal for spool types 4/2	
<b>Switch-on time</b> Solenoid change-over from the operating to the centre position	(ms)	3 positions valve	60
		2 positions valve	85
<b>Switch-off time</b> Solenoid change-over from the operating to the centre position	(ms)	3 positions valve	45
		2 positions valve	50
<b>Filtration</b>	NAS 1638	8	
<b>Ambient temperature range</b>	°C [°F]	+50 [122]	
<b>Coil temperature range</b>	°C [°F]	+180 [356]	
<b>Power</b>	W	29 (12V supply voltage - 36W)	
<b>Voltage</b>	V	12, 24, 48, 110, 230	

The switch-on and switch-off times apply to 24 V DC solenoids.

**ΔP-Q Performance curves**

Measured at 50°C [122°F] and viscosity of 32 mm<sup>2</sup>/s [148 SUS].

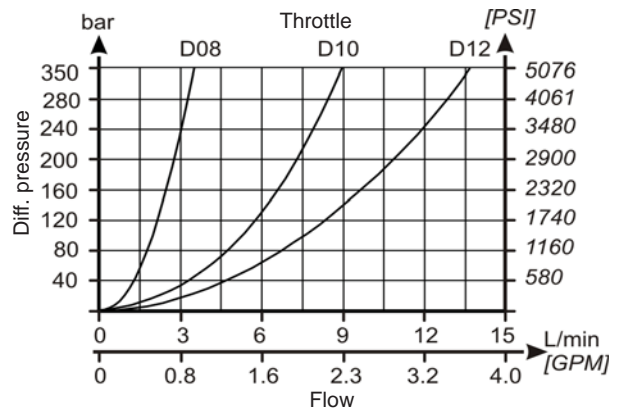
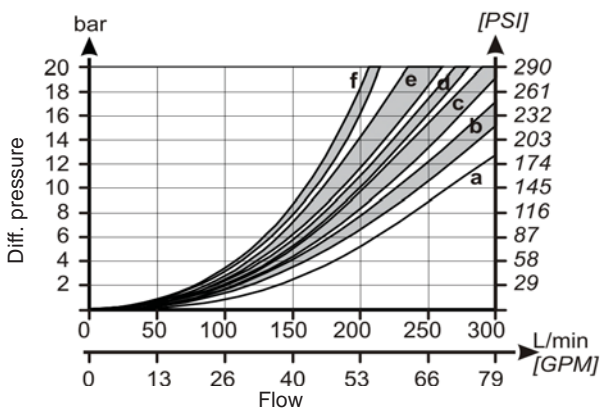

Spool type	P-A	P-B	A-T	B-T	P-T
1, R1, 51B, 51A, F51, R51	e	e	e	f	-
2, R2	a	b	c	e	f
3, R3	b	b	c	d	-
4, R4	b	c	c	e	-
5, R5	b	c	c	e	-
6, R6	b	c	d	e	-

See Model Code for spool type choice.



**Cartridge throttle**

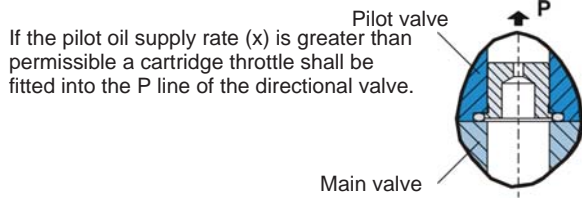

**Pre-load valve**

In valves with a low pressure bypass and internal pilot oil feed, minimum pilot pressure is obtained by installing a pre-load valve in the P-port of the main valve.  
The cracking pressure is approx. 4,5 to 6 bar [65 to 87 PSI].

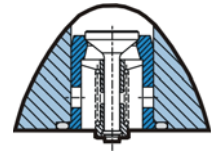

**Pressure reducing valve**

The pressure reducing valve used when the pilot oil "X" pressure exceeds the permissible limit  $p = 250$  bar [3 626 PSI].

**Throttle check valve**

The throttle check valve used for setting the supply flow rate of the pilot oil to the pressure chambers. Simultaneously, the change-over speed of the main control spool is adjusted. In this way a smoother change-over, without hydraulic shocks is provided.

**Dimensions**

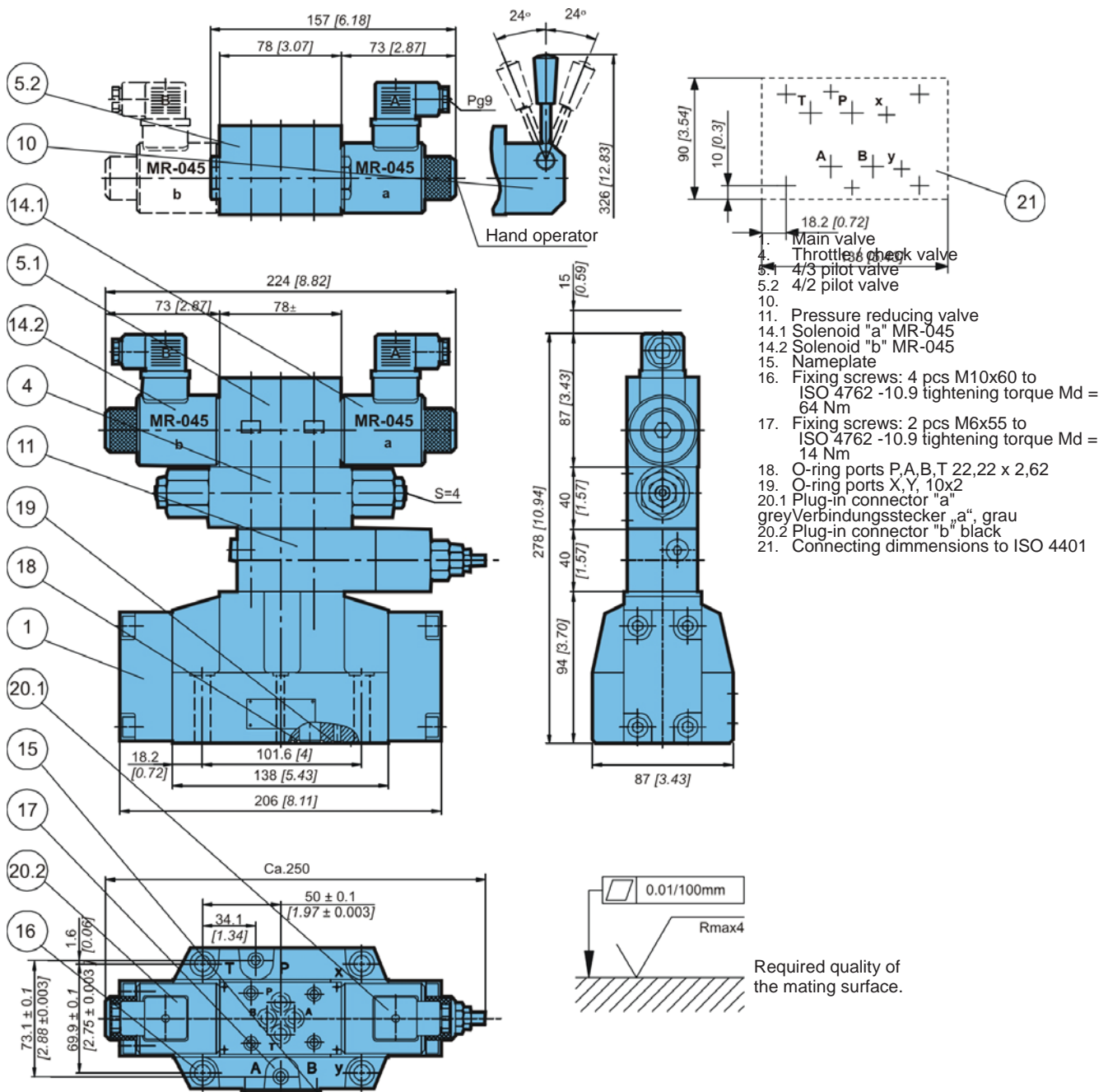

Mechanically operated

Hydraulically operated

Electrically operated

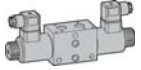

**Model code**

**K V** - **4** /    **1 6** -    -    -   

**Number of control spool positions**

Two positions	2
Three positions	3

**Manual override option**

Emergency manual override	No designation
Manual override with rubber cover	G

**Pilot oil supply and discharge**

Three positions

Two positions

**Spool types**

	1
	2
	3
	4
	5
	6
	R1
	R2
	R3
	R4
	R5
	R6
	R51
	F51
	51A
	51B

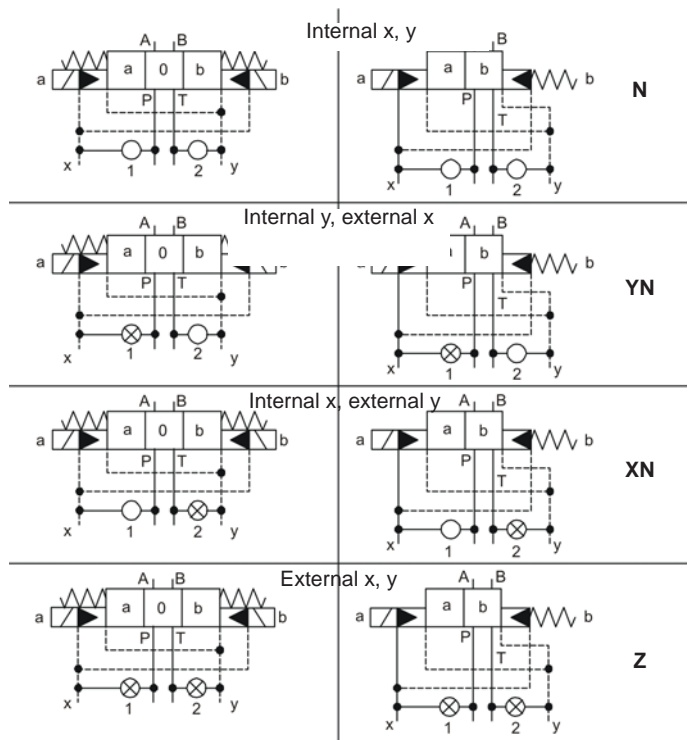

For supply and discharge with spool type 2 and 3, refer to the features table.

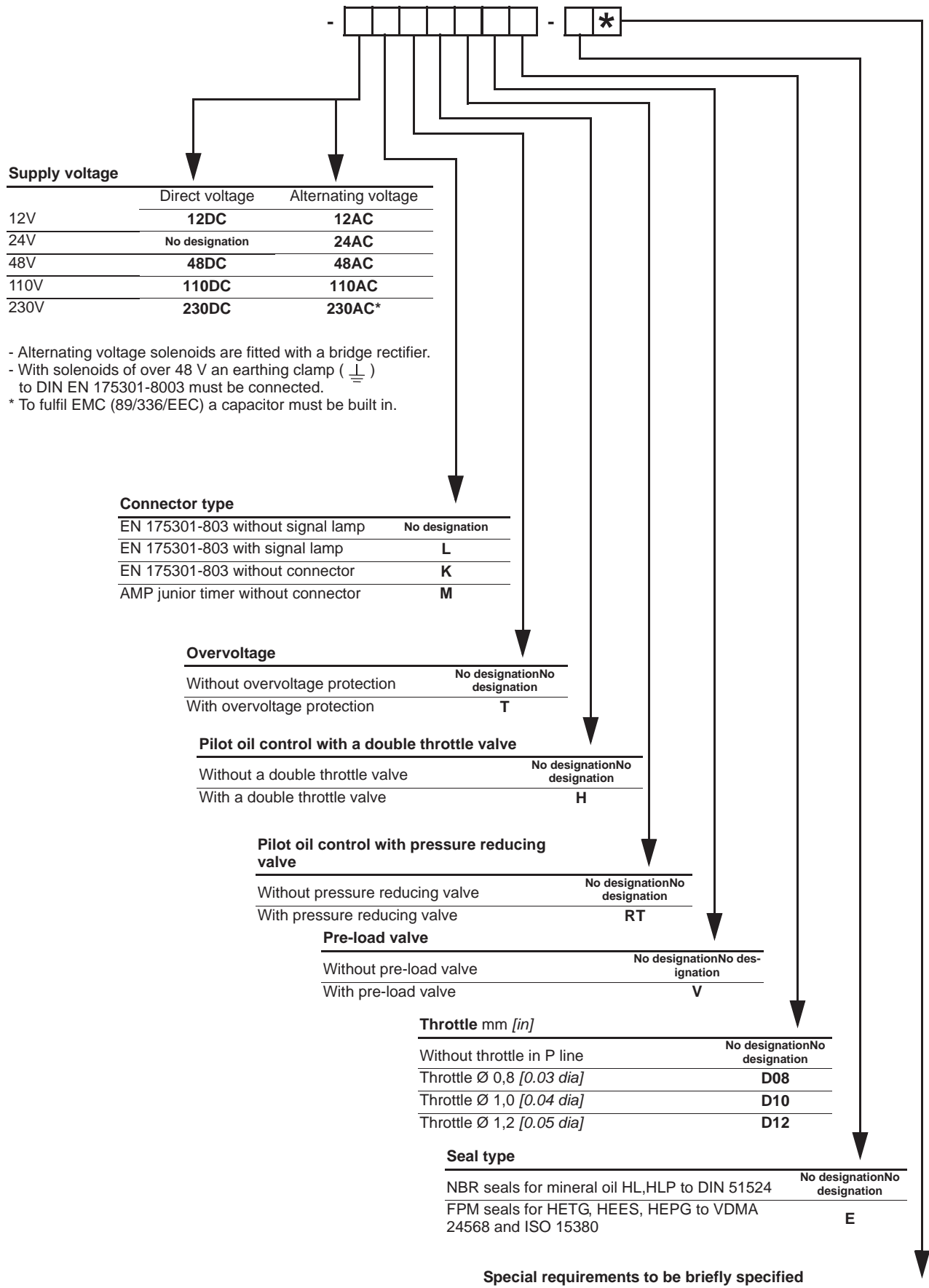

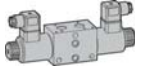



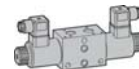

## 4/2, 4/3 WAY DIRECTIONAL VALVE KV-3KO

- NG 6
- Up to 250 bar [5 625 PSI]
- Up to 40 L/min [10.6 GPM]
- Connection diagram and connecting dimensions to ISO 4401.
- Different types of plug-in connectors.
- 3-chamber model.
- Optimized flow paths for low losses of pressure.
- Wet pin solenoid with interchangeable coil.
- Manual emergency control.
- Protection of solenoid IP 65 to EN 60529 / IEC 60529.
- Fulfil EMC (89/336/EEC).

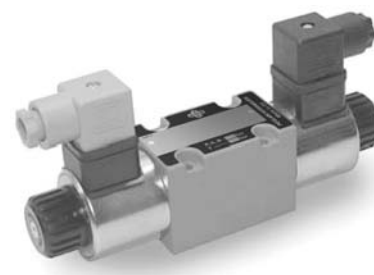

KV-4/3-3KO-6

### Operation

Directional valves type KV-3KO with direct solenoid operation control the direction of the hydraulic medium flow.

These directional valves consist of a housing (1), a control spool (3), and one solenoid (2) with two return springs (4) in 4/2-way directional valves, and two solenoids (2) with two return springs (4) in 4/3-way directional valves. In 4/3-way directional valves the centre position of the control spool is the neutral position. The change-over to the operating position (a) and (b) is done by energizing the solenoids (2) "a" and "b" respectively, whereby the solenoid plunger acts on the control spool (3) via the operating pin (5), thus clearing the corresponding flow ways and establishing relevant links between ports A, B, P, and T.

When the solenoid (2) is de-energized, the control spool (3) is returned to its neutral position by the return spring (4). The change-over can be done manually by pressing the emergency hand operator (6).

### Hydraulic symbols

Spool types

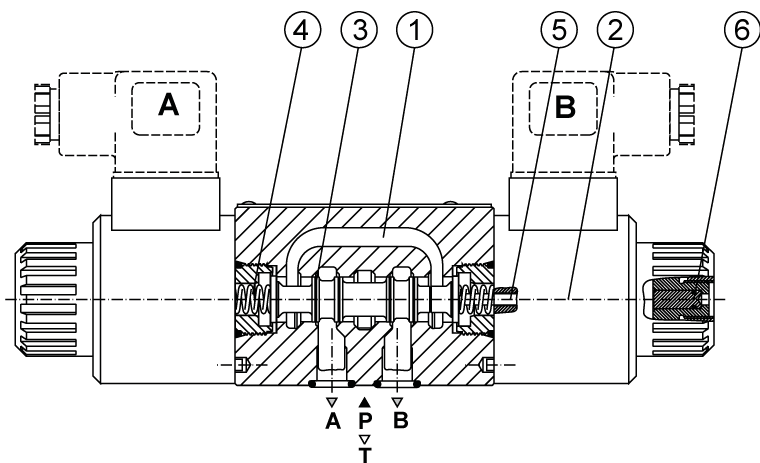
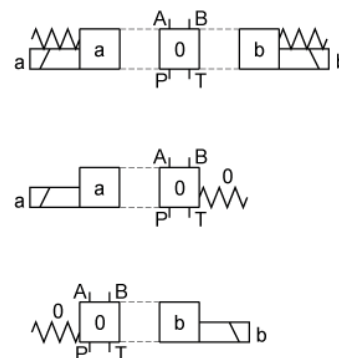

Mechanically operated

Hydraulically operated

Electrically operated