

Axial piston pumps

variable displacement, mechanical controls

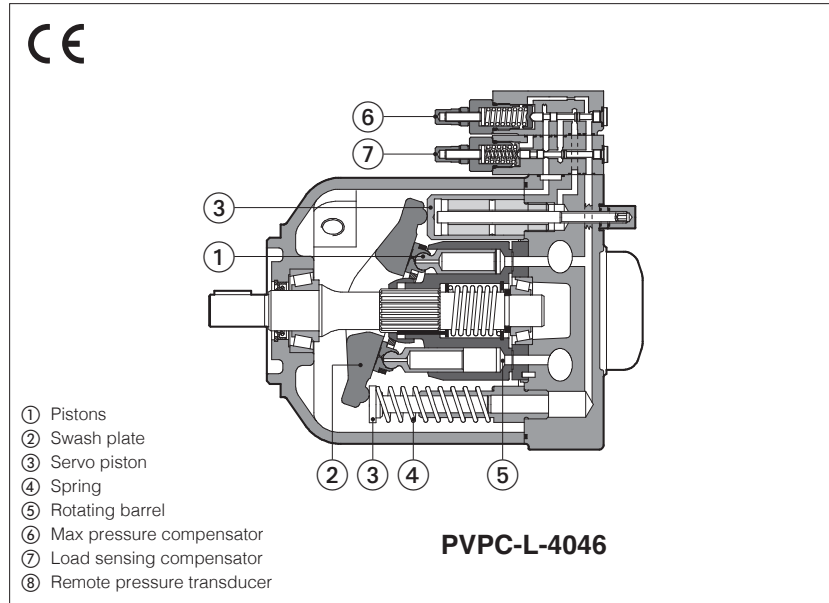

PVPC

Variable displacement axial piston pumps with swash plate design suited for high pressure open circuits.

They are characterized by low noise emission, short response time and flexible operation thanks to the wide range of mechanical controls, see section 12 and 13.

For PVPC pumps with electrohydraulic proportional controls, see tech table AS170.

SAE J744 mounting flange and shaft.

Max displacement (cm ³ /rev)	Max pressure working (bar)	Max pressure peak (bar)
29, 46, 73, 140, 160	280	350
88	250	315

1 MODEL CODE

PVPC	XA	-	C	-	4046	/	1	-	D	-	X	24DC	*	/	*	
Variable displacement axial piston pump																Seals material, see section 5 : - = NBR PE = FKM
Option for pumps with through shaft (1): XA = intermediate flange SAE A XB = intermediate flange SAE B XC = intermediate flange SAE C (only for size 5073 and 5090)																
Type of control, see sections 12 and 13 : C = manual pressure compensator (2) CH = manual pressure compensator, with venting R = remote pressure compensator (1) L = load sensing (pressure & flow) LW = constant power (combined pressure & flow) (3) For electrohydraulic proportional controls, see tech table AS170																
Size and max displacement (4): 3029 = size 3 - displacement 029 cm ³ /rev 4046 = size 4 - displacement 046 cm ³ /rev 5073 = size 5 - displacement 073 cm ³ /rev 5090 = size 5 - displacement 088 cm ³ /rev 6140 = size 6 - displacement 140 cm ³ /rev 6160 = size 6 - displacement 160 cm ³ /rev																
Coil voltage, see section 4 (only for CH version)																
X = without connector (only for CH version) See section 4 for available connectors, to be ordered separately																
Direction of rotation, viewed at the shaft end: D = clockwise S = counterclockwise																
Shaft, SAE Standard (5): 1 = keyed 5 = splined																
Series number																

(1) Not available for PVPC size 6, see section 13

(2) For PVPC size 6 the compensator type C can be also used for remote pressure control, see section 13

(3) For PVPC-LW the requested value of torque setting or power and speed must be specified in the pump order, e.g. 70 Nm or 10 kW at 1450 RPM

(4) Optional intermediate displacements 35 and 53 cm³/rev are available on request

(5) Pumps with ISO 3019/2 mounting flange and shaft (option /M) are available on request

2 GENERAL CHARACTERISTICS

Assembly position - see section 7	Any position. The drain port must be on the top of the pump. Drain line must be separated and unrestricted to the reservoir and extended below the oil level as far from the inlet as possible. Suggested maximum line length is 3 m.
Ambient temperature range	Standard = -25°C ÷ +80°C / PE option -15°C ÷ +80°C
Storage temperature	Standard = -40°C ÷ +70°C / PE option -20°C ÷ +70°C
Surface protection (pump body)	Black painting RAL9005
Compliance	RoHS Directive 2011/65/EU as last update by 2015/863/EU REACH Regulation (EC) n°1907/2006

3 HYDRAULIC CHARACTERISTICS - based on mineral oil ISO VG 46 at 50 °C

PVPC size	3029	4046	5073	5090	6140	6160						
Max displacement (cm ³ /rev)	29	46	73	88	140	160						
Theoretical max flow at 1450 rpm (l/min)	42	66,7	105,8	127,6	203	232						
Max pressure working / peak (bar)	280 / 350	280 / 350	280 / 350	250 / 315	280 / 350 (1)	280 / 350 (1)						
Min/Max inlet pressure (bar abs.)	0,8 / 25	0,8 / 25	0,8 / 25	0,8 / 25	0,8 / 25	0,8 / 25						
Max pressure on drain port (bar abs.)	1,5	1,5	1,5	1,5	1,5	1,5						
Power consumption at 1450 rpm and at max pressure and displacement (Kw)	20	32	52	55	105	120						
Max torque on the shaft (shaft type) (Nm)	Type 1 210	Type 5 270	Type 1 350	Type 5 440	Type 1 670	Type 5 810	Type 1 670	Type 5 810	Type 1 1300	Type 5 1660	Type 1 1300	Type 5 1660
Max torque at max working pressure (Nm)	128		203		328		350		780		890	
Speed rating (rpm)	500 ÷ 3000		500 ÷ 2600		500 ÷ 2600		500 ÷ 2200		500 ÷ 2200		500 ÷ 2000	
Body volume (l)	0,7		0,9		1,5		1,5		2,8		2,8	

(1) The maximum pressure can be increased to 350 bar (working) and 420 bar (peak) after detailed analysis of the application and of the pump working cycle

4 ELECTRICAL CHARACTERISTICS - for PVPC-CH

Insulation class	H
Connector protection degree	IP 65
Relative duty factor	100%
Supply voltage tolerance	± 10%

4.1 COIL VOLTAGE - only for CH version

Average values based ambient/coil temperature of 20°C.

External supply nominal voltage ±10%		Voltage code	Power consumption	Nominal current	Coil characteristics
DIRECT CURRENT	12 DC 24 DC	12DC 24DC	19,2 W	1,61 A 0,80 A	Insulation Class: H Protection degree: IP65

4.2 ELECTRIC CONNECTORS ACCORDING TO DIN 43650 - to be ordered separately

Code of connector	Description
SP-666	Connector IP-65
SP-667	Connector IP-65 but with built-in signal led

5 SEALS AND HYDRAULIC FLUIDS - for other fluids not included in below table, consult our technical office

Seals, recommended fluid temperature	NBR seals (standard) = -25°C ÷ +80°C, with HFC hydraulic fluids = -20°C ÷ +50°C FKM seals (/PE option) = -20°C ÷ +80°C		
Recommended viscosity	15÷35 mm ² /s - max allowed range: min 10 cSt (at 80°C) - max 1500 cSt at cold startup (-25°C)		
Max fluid contamination level	normal operation	ISO4406 class 20/18/13 NAS1638 class 9	see also filter section at www.atos.com or KTF catalog
	longer life	ISO4406 class 18/16/11 NAS1638 class 7	
Hydraulic fluid	Suitable seals type	Classification	Ref. Standard
Mineral oils	NBR, FKM	HL, HLP, HLPD, HVLP, HVLPD	DIN 51524
Flame resistant without water	FKM	HFDU, HFDR (1)	ISO 12922
Flame resistant with water	NBR	HFC (1)	

(1) See section 6

6 PERFORMANCE RESTRICTIONS WITH FLAME RESISTANT FLUIDS

6.1 HFDU and HFDR - Phosphate ester

PVPC size	3029	4046	5073	5090	6140 / 6160
Max pressure working / peak (bar)	200 / 240				(2)
Max speed (1) (rpm @ VMAX)	2050	1850	1700	1550	
Ambient temperature range (°C)	-10 ÷ +80				
Bearing life (% of bearing life with mineral oil) (%)	90				

(1) With an inlet pressure of 1 bar abs

(2) For information about size 6140, contact Atos technical office

6.2 HFC - Water-glycol (35 ÷ 55 % of water)

PVPC size	3029	4046	5073	5090	6140 / 6160
Max pressure working / peak (bar)	180 / 210				(2)
Max speed (1) (rpm @ VMAX)	2050	1850	1700	1550	
Ambient temperature range (°C)	-10 ÷ +60				
Bearing life (% of bearing life with mineral oil) (%)	40				

(1) With an inlet pressure of 1 bar abs

(2) For information about size 6140 and 6160, contact Atos technical office

7 INSTALLATION POSITION

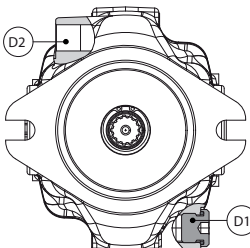
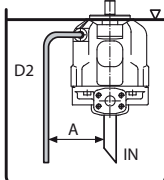
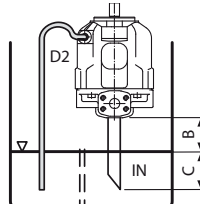
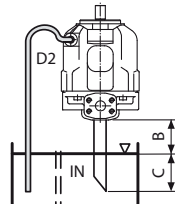
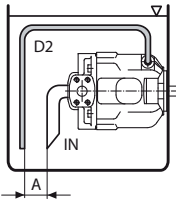
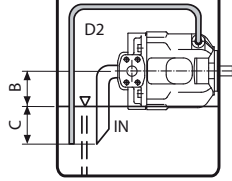
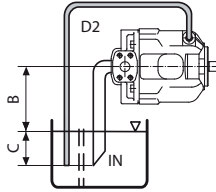
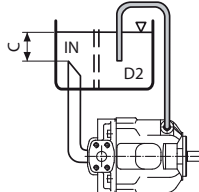
 <p>The pump is supplied with drain D2 open, and D1 plugged. Before installation fill the pump with hydraulic oil for at least 3/4 of its volume, keeping it in horizontal position. With exception of pump mounted below the oil level, we recommend to interpose a baffle plate between inlet and drain line.</p>	VERTICAL INSTALLATION			
		 <p>INSIDE THE TANK Minimum oil level equal or above the pump mounting surface. A ≥ 200mm</p>	 <p>INSIDE THE TANK Minimum oil level below the pump mounting surface. Minimum inlet pressure = 0,8 bar absolute B ≤ 800mm, C = 200mm</p>	 <p>OUTSIDE THE TANK, above oil level Minimum inlet pressure = 0,8 bar absolute B ≤ 800mm, C = 200mm</p>
	HORIZONTAL INSTALLATION			
	 <p>INSIDE THE TANK Minimum oil level equal or above the pump mounting surface. A ≥ 200mm</p>	 <p>INSIDE THE TANK Minimum oil level below the pump mounting surface. Minimum inlet pressure = 0,8 bar (absolute) B ≤ 800mm, C = 200mm</p>	 <p>OUTSIDE THE TANK, above oil level Minimum inlet pressure = 0,8 bar (absolute) B ≤ 800mm, C = 200mm</p>	 <p>OUTSIDE THE TANK, below oil level C = 200mm</p>

IN: inlet line - D2: drain line - A: minimum distance between inlet and drain line - B+C: permissible suction height - C: inlet line immersion dept

8 MAX PERMISSIBLE LOAD ON DRIVE SHAFT

PVPC size		3029	4046	5073	5090	6140	6160
F_{ax} = axial load		N	1000	1500	2000	2000	2000
F_{rad} = radial load		N	1500	1500	3000	3000	3000

9 VARIATION OF MAX SPEED VS INLET PRESSURE

Inlet pressure bar abs.	Displacement %					% variation of the max. speed
	65	70	80	90	100	
0,8	120	115	105	97	90	
0,9	120	120	110	103	95	
1,0	120	120	115	107	100	
1,2	120	120	120	113	106	
1,4	120	120	120	120	112	
1,6	120	120	120	120	117	
2,0	120	120	120	120	120	

Example

Displacement: 80% - Inlet pressure: 1,0 bar - Speed: 115%

10 MAX DISPLACEMENT SETTING

		<p>① Locking displacement limiter screw</p> <p>② Displacement setting</p>					
PVPC size		3029	4046	5073	5090	6140	6160
Max displacement setting range	from ÷ to	20,1 ÷ 28,7	31,8 ÷ 45,4	36,8 ÷ 73,6	44,0 ÷ 87,9	70 ÷ 140	80 ÷ 160
One turn of screw changes pump displacement by approximately	cm ³ /rev	1,5	2,2	3,2	3,2	6,0	6,0
For locking displacement limiter screw	mm	14	14	17	17	19	19
For displacement setting	mm	4	4	5	5	6	6
Tightening torque	Nm	15 ± 1	15 ± 1	15 ± 1	15 ± 1	20 ± 1	20 ± 1

11 DIAGRAMS at 1450 rpm (based on mineral oil ISO VG 46 at 50°C)

11.1 Noise level curves

Ambient noise levels measured in compliance with ISO 4412-1 oleohydraulics - Test procedure to define the ambient noise level - Pumps Shaft speed: 1450 rpm.

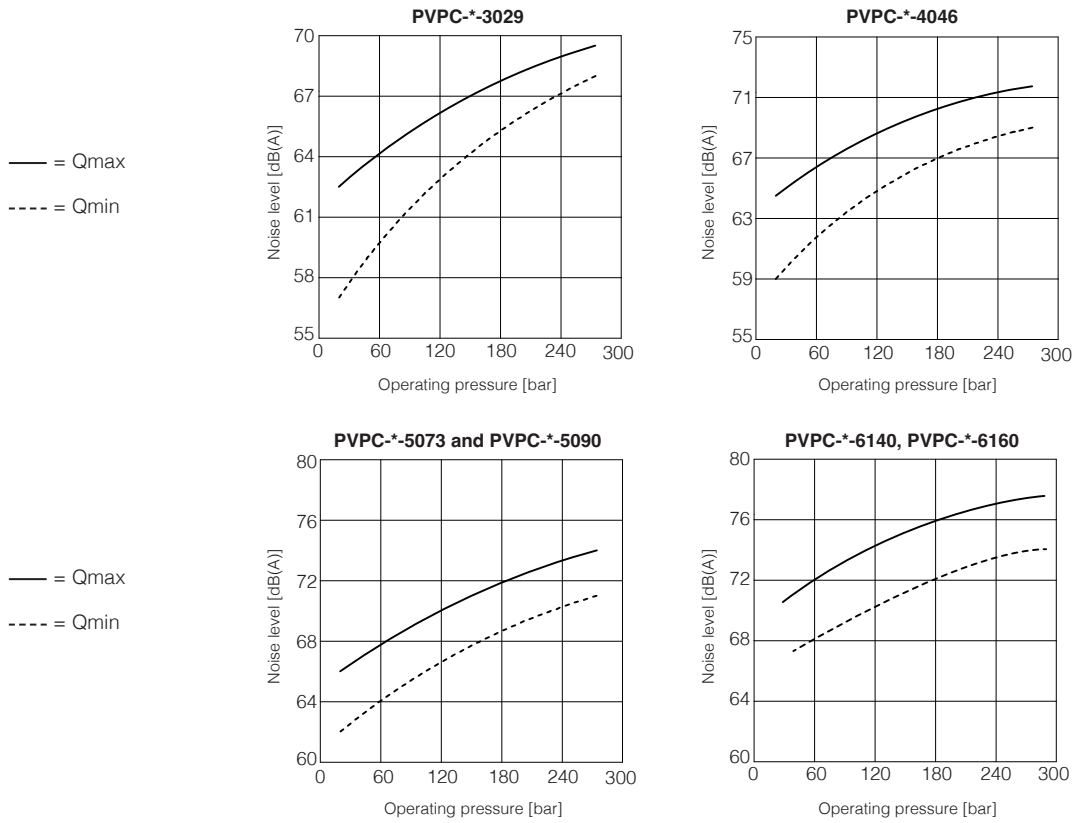

11.2 Operating limits

- 1 = Volumetric efficiency
- 2 = Overall efficiency
- 3 = Flow versus pressure curve
- 4 = Power consumption with full flow
- 5 = Power consumption at null flow

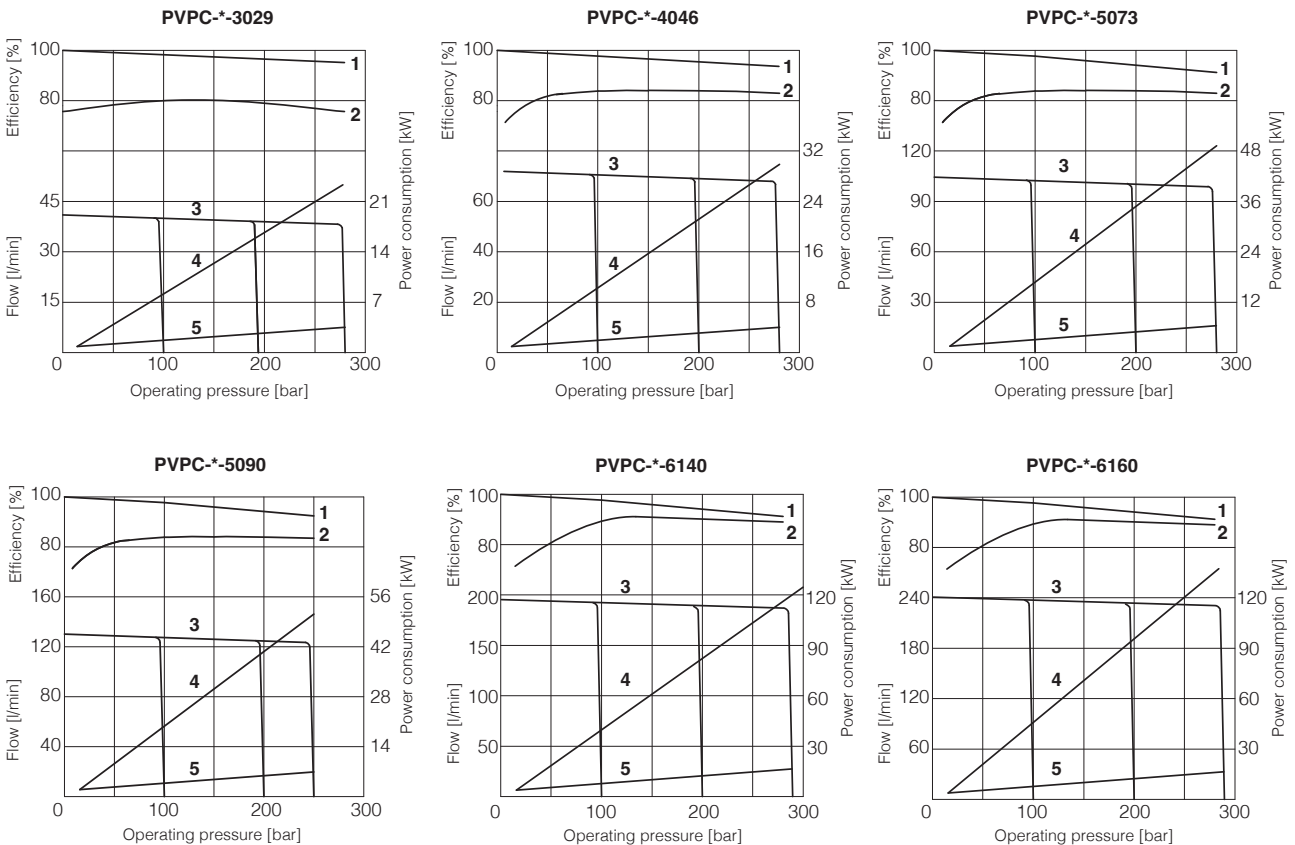

11.3 Response times

Response times and pressure peak due to variation 0% to 100% and 100% to 0% of the pump displacement, obtained with an instantaneously opening and shut-off of the delivery line.

Pump type	T1 (ms)	T2 (ms)
PVPC-*-3029	140	36
PVPC-*-4046	140	42
PVPC-*-5073	160	44
PVPC-*-5090	160	44
PVPC-*-6140	170	100
PVPC-*-6160	180	110

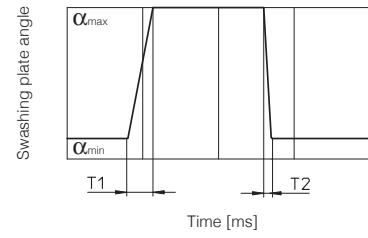

11.4 Minimum power/torque setting for PVPC-LW (constant power regulator)

For the pump correct operation, the power / torque factory setting has to be higher than the values reported in the below table. In case of lower power/torque setting values, the regulator limits the maximum working pressure to a value lower than the standard setting.

Note: please specify the requested value of torque setting or power and speed in the PVPC-LW pump order, e.g. 70 Nm or 10 kW at 1450 RPM

Pump type	Minimum torque (Nm)	Minimum power (Kw)
PVPC-LW-3029	43	6,7
PVPC-LW-4046	68	10,7
PVPC-LW-5073	113	17,8
PVPC-LW-5090	132	20,7
PVPC-LW-6140	197	30
PVPC-LW-6160	220	34

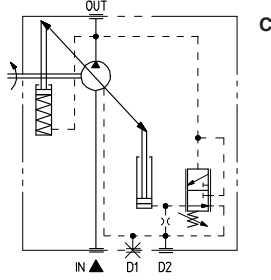

Manual pressure compensator

The pump displacement is zeroed when the line pressure approaches the setting pressure of the compensator.

Compensator setting range:
 20 ÷ 280 bar for 3029, 4046, 5073
 20 ÷ 250 bar for 5090

Compensator standard setting:
 280 bar for 3029, 4046, 5073
 250 bar for 5090

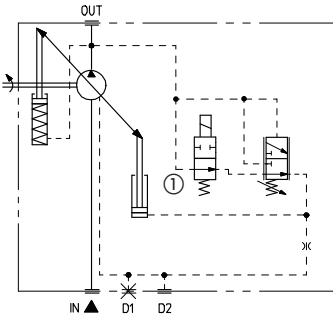
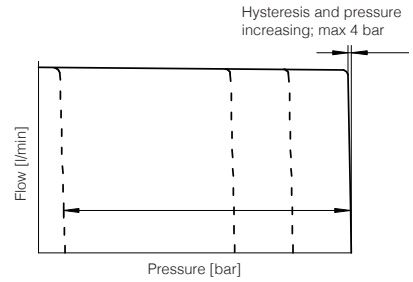

CH

Manual pressure compensator with venting

As C plus venting function, when a long unloading time is required and heat generation and noise have to be kept at lowest level.

Venting valve solenoid voltage, see section 4
 Venting valve OFF = null displacement
 Venting valve ON = max displacement

Compensator setting range:
 20 ÷ 280 bar for 3029, 4046, 5073
 20 ÷ 250 bar for 5090, 6140

Compensator standard setting:
 280 bar for 3029, 4046, 5073
 250 bar for 5090, 6140

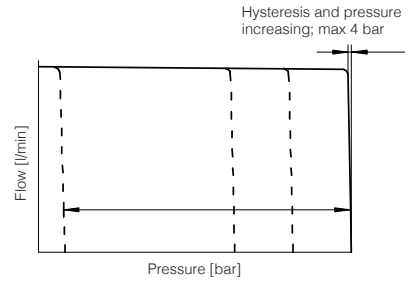

① solenoid venting valve

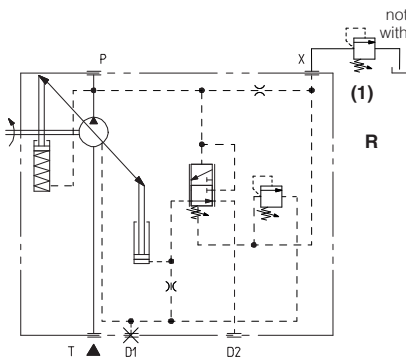

R

Remote pressure compensator

As C, but predisposed with X piloting port for connection of a remote pilot relief valve (1).

Compensator setting range:
 20 ÷ 280 bar for 3029, 4046, 5073
 20 ÷ 250 bar for 5090

Compensator standard setting:
 280 bar for 3029, 4046, 5073
 250 bar for 5090

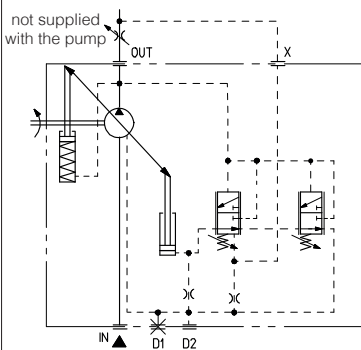
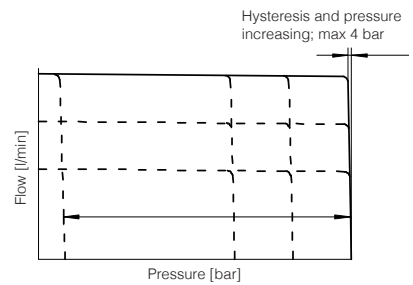

L

Load sensing

The pump displacement is automatically adjusted to maintain a constant (load independent) pressure drop across an external throttle. Changing the throttle regulation, the pump flow is consequently adjusted.

Load sensing control always incorporates an hydraulic compensator to limit the maximum pressure.

Compensator setting range:
 20 ÷ 280 bar for 3029, 4046, 5073
 20 ÷ 250 bar for 5090

Compensator standard setting:
 280 bar for 3029, 4046, 5073
 250 bar for 5090

Differential pressure setting range: 10 ÷ 40 bar
 Differential pressure standard setting: 14 bar

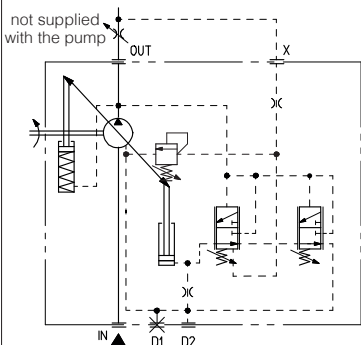
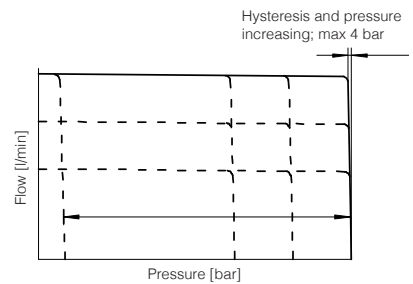

LW

Constant power

In order to achieve a constant drive torque with varying operating pressure. The swashing angle and therefore the outlet flow is varied so that the product of flow and pressure remains constant.

See section 11.4 for min power/torque setting

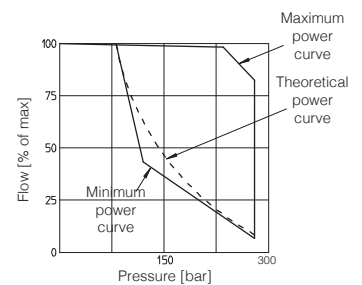

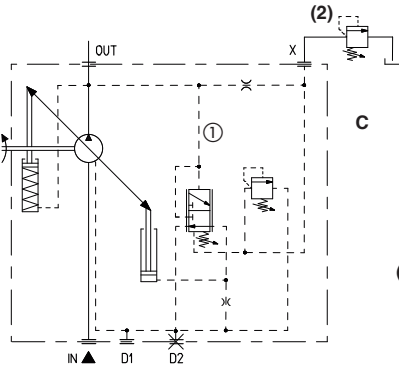

Manual pressure compensator

The pump displacement is zeroed when the line pressure approaches the setting pressure of the compensator.

Compensator setting range: 20 ÷ 280 bar

Compensator standard setting: 280 bar

Note: do not modify the setting of differential pressure compensator (1)

(2): The pump max pressure can be remotely controlled as -R control type, connecting the X port to a pilot relief valve. The valve is not supplied with the pump, it needs to be ordered separately

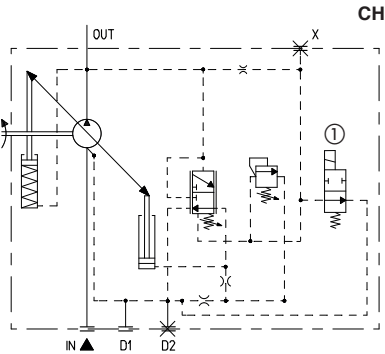
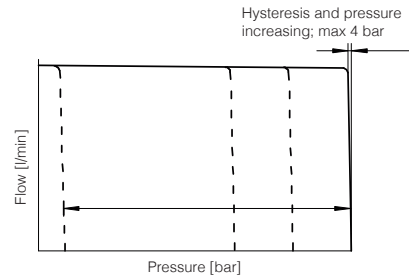

Manual pressure compensator with venting

As C plus venting function, when a long unloading time is required and heat generation and noise have to be kept at lowest level.

Venting valve solenoid voltage, see section 4

Venting valve OFF = null displacement

Venting valve ON = max displacement

Compensator setting range: 20 ÷ 280 bar

Compensator standard setting: 280 bar

(1) solenoid venting valve

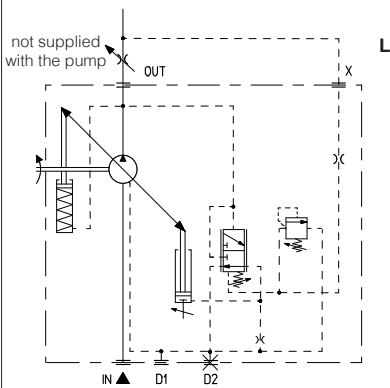
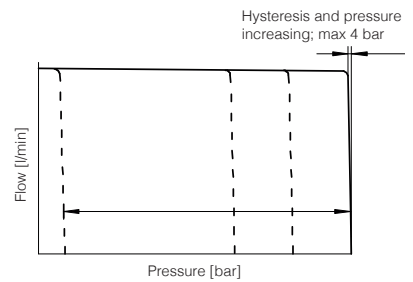

Load sensing

The pump displacement is automatically adjusted to maintain a constant (load independent) pressure drop across an external throttle. Changing the throttle regulation, the pump flow is consequently adjusted.

Load sensing control always incorporates an hydraulic compensator to limit the maximum pressure.

Compensator setting range: 20 ÷ 280 bar

Compensator standard setting: 280 bar

Differential pressure setting range: 10 ÷ 40 bar

Differential pressure standard setting: 14 bar

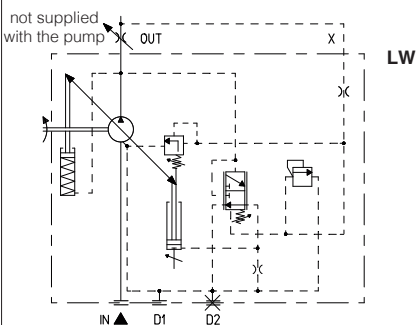
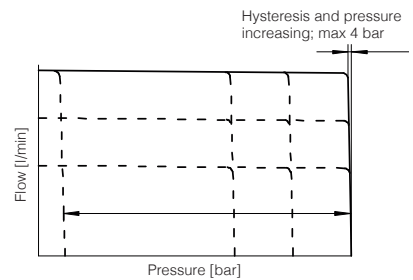

Constant power

In order to achieve a constant drive torque with varying operating pressure. The swashing angle and therefore the outlet flow is varied so that the product of flow and pressure remains constant.

See section 11.4 for min power/torque setting

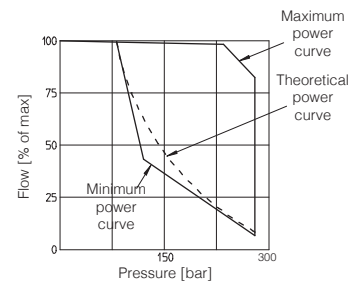

14 INSTALLATION DIMENSIONS OF PVPC-* -3029: BASIC VERSION "C" CONTROL

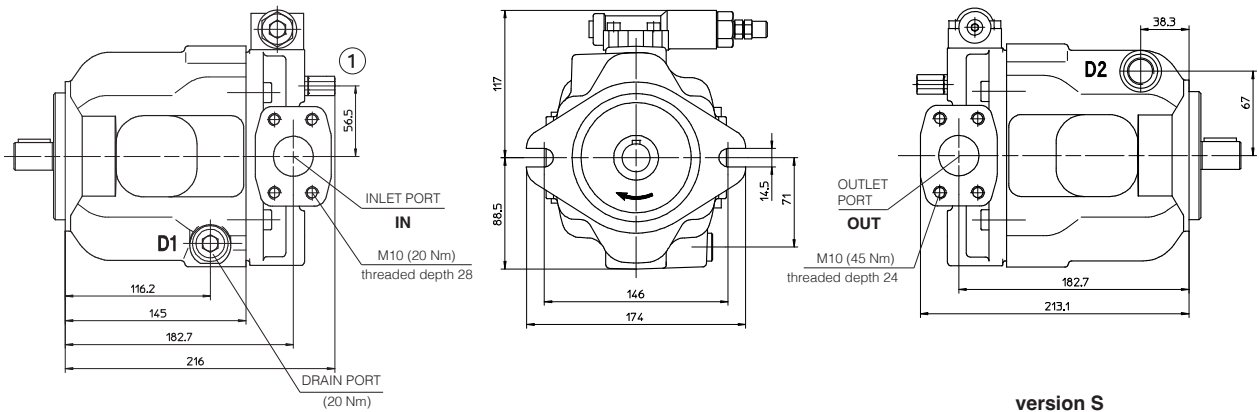

PORTS DIMENSION

- IN** = Flange SAE 3000 1 1/4"
- OUT** = Flange SAE 6000 3/4"
- D1, D2** = 1/2" BSPP
- ① = Screw for max displacement limiter
In case of double pump the screw is not available for version XB

Mass [kg]	
PVPC-* -3029	18

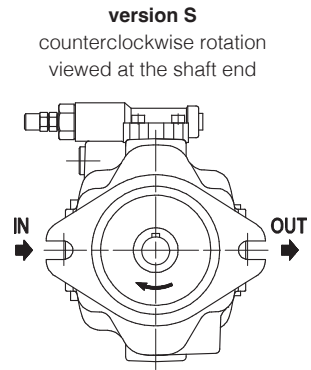
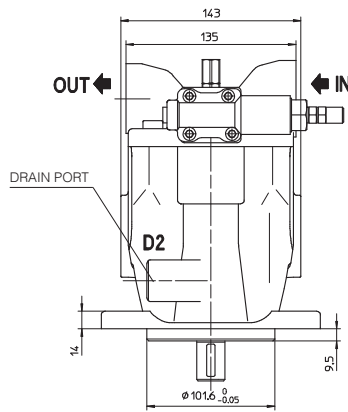

Pumps with counterclockwise rotation (S) have the IN and OUT inverted and consequently the position of the compensators

SHAFT TYPE "1"

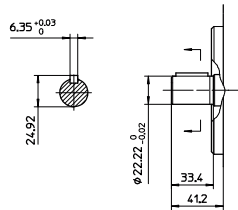

SHAFT TYPE "5"

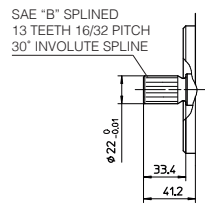

CODE XA - INTERMEDIATE FLANGE SAE "A" FOR PFE-31

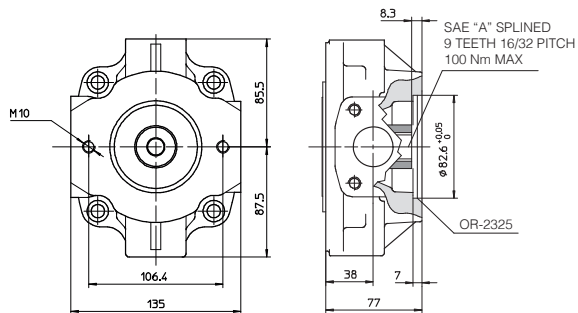

CODE XB - INTERMEDIATE FLANGE SAE "B" FOR PFE-41 or PVPC-3029

screw for max displacement setting not available

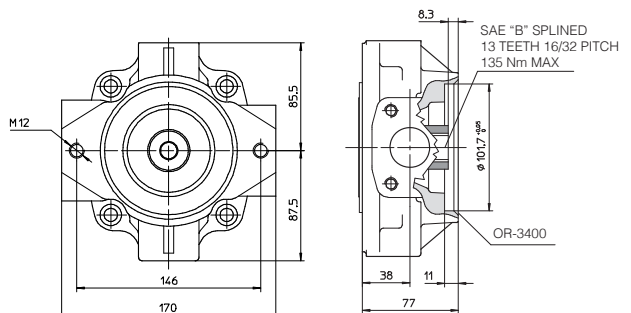

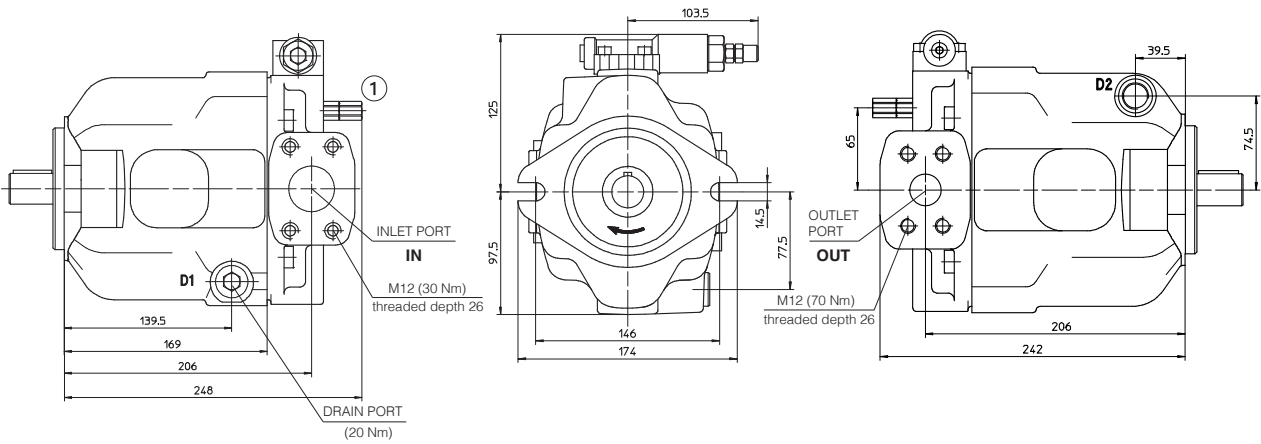

PORTS DIMENSION

- IN = Flange SAE 3000 1 1/2"
- OUT = Flange SAE 6000 1"
- D1, D2 = 1/2" BSPP
- ① = Screw for max displacement limiter

Mass [kg]	
PVPC-*-4046	24

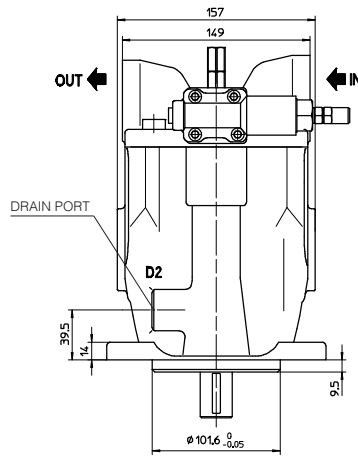

version S
counterclockwise rotation
viewed at the shaft end

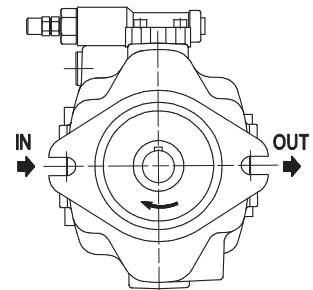

Pumps with counterclockwise rotation (S) have the IN and OUT inverted and consequently the position of the compensators

SHAFT TYPE "1"

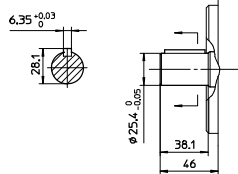

SHAFT TYPE "5"

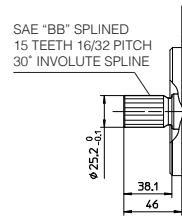

CODE XA - INTERMEDIATE FLANGE SAE "A" FOR PFE-31

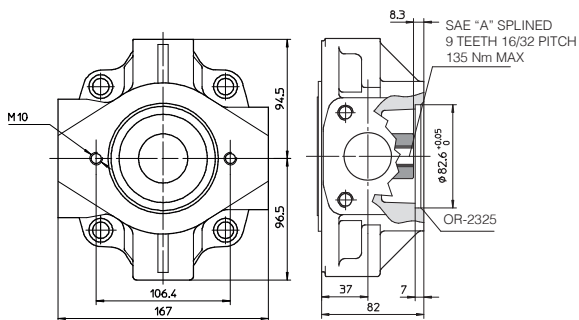

CODE XB - INTERMEDIATE FLANGE SAE "B" FOR PFE-41, PVPC-3029 or PVPC-4046 (see note 1)

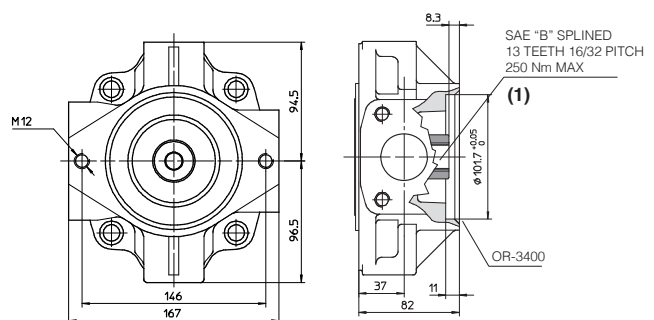

(1) For coupling with PVPC-4046 rear pump, the coupling code G-PVPC-40/46 (SAE BB splined, 15 teeth) must be ordered separately
Drawing shows pumps with clockwise rotation (option D): pumps with counterclockwise rotation (option S) will have inlet and outlet ports inverted

16 INSTALLATION DIMENSIONS OF PVPC-*-5073 and PVPC-*-5090: BASIC VERSION "C" CONTROL

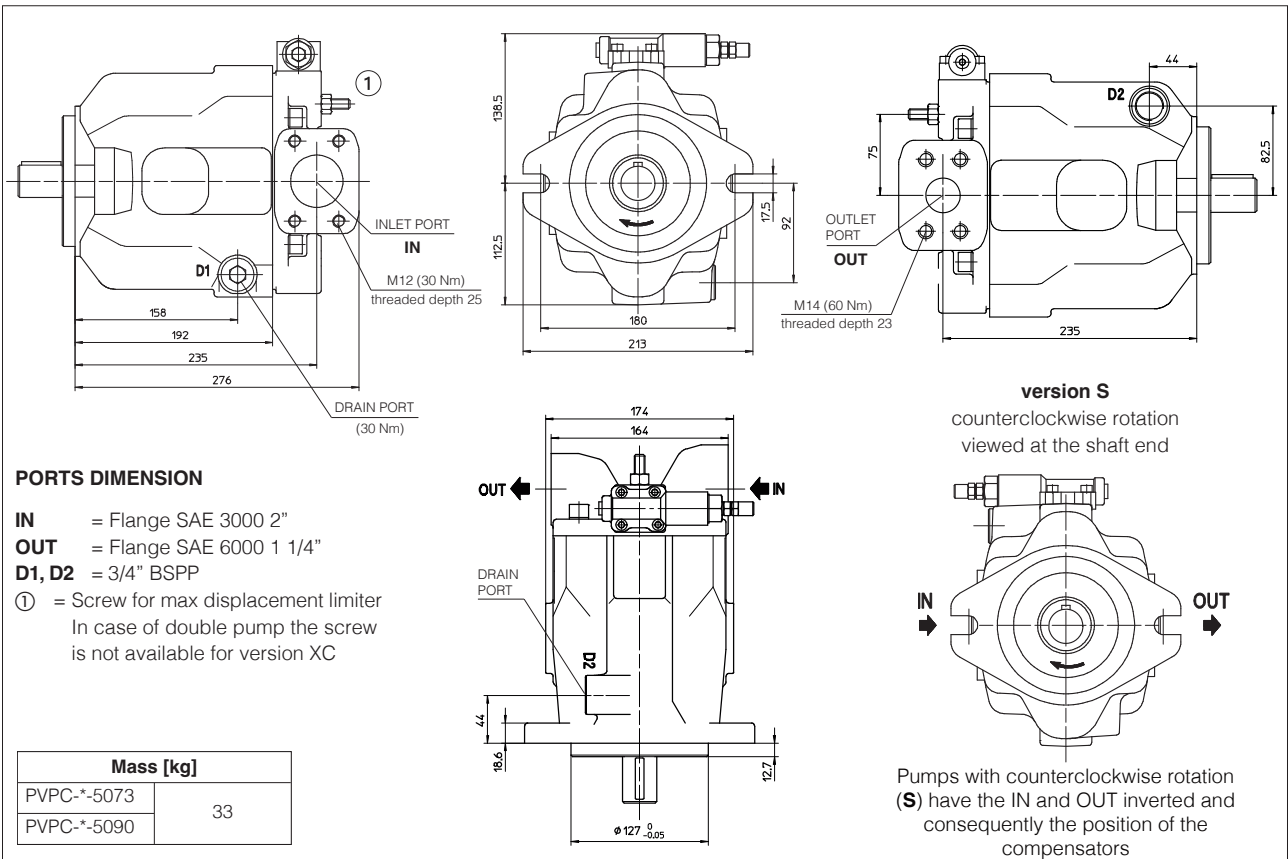

SHAFT TYPE "1"

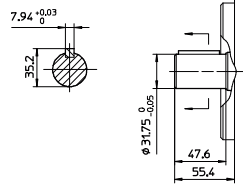

SHAFT TYPE "5"

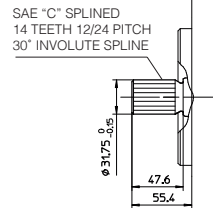

CODE XA - INTERMEDIATE FLANGE SAE "A" FOR PFE-31

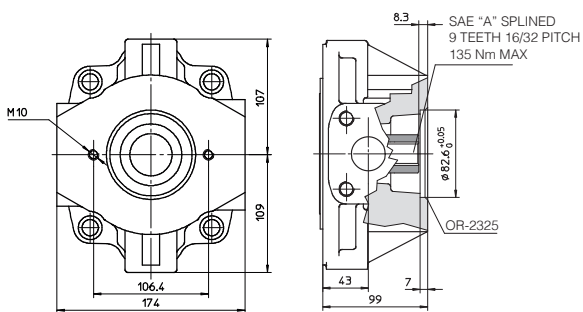

CODE XB - INTERMEDIATE FLANGE SAE "B" FOR PFE-41, PVPC-3029 or PVPC-4046 (see note 1)

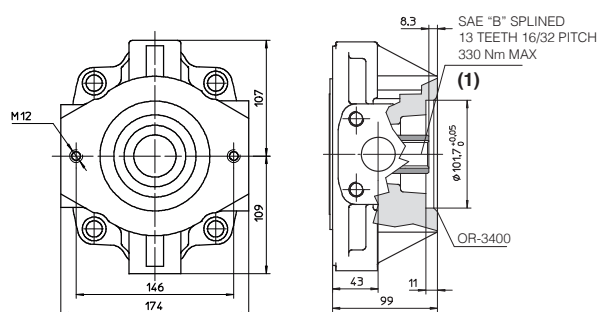

CODE XC - INTERMEDIATE FLANGE SAE "C" FOR PFE-51, PVPC-5073 or PVPC-5090
screw for max displacement setting not available

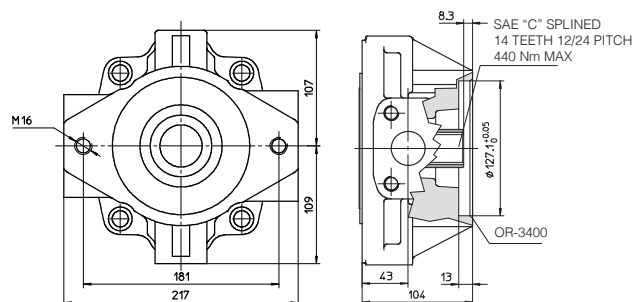

(1) For coupling with PVPC-4046 rear pump, the coupling code G-PVPC-73/46 (SAE BB splined, 15 teeth) must be ordered separately
Drawing show pumps with clockwise rotation (option D): pumps with counterclockwise rotation (option S) will have inlet and outlet ports inverted

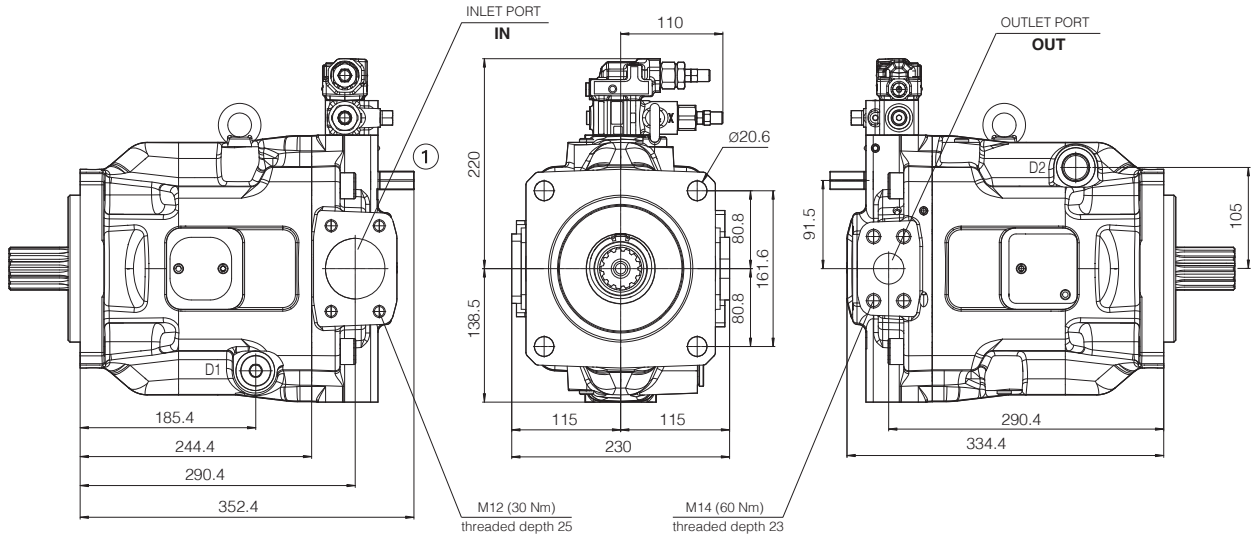

PORTS DIMENSION

- IN** = Flange SAE 3000 2 1/2"
- OUT** = Flange SAE 6000 1 1/4"
- D1, D2** = 1 1/16"-12UNF
- ① = Screw for max displacement limiter

Mass [kg]	
PVPC-*-6140	69
PVPC-*-6160	

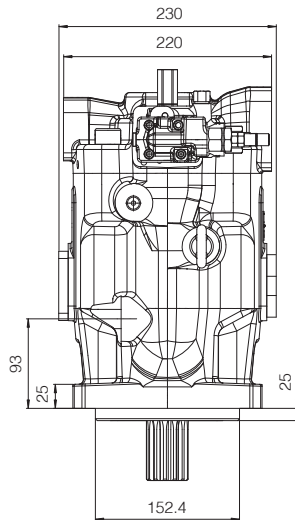

version S
counterclockwise rotation
viewed at the shaft end

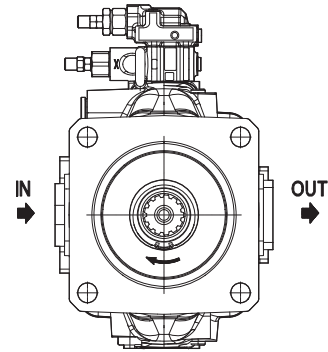

Pumps with counterclockwise rotation
(S) have the IN and OUT inverted and
consequently the position of the
compensators

SHAFT TYPE "1"

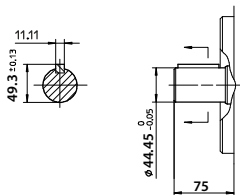

SHAFT TYPE "5"

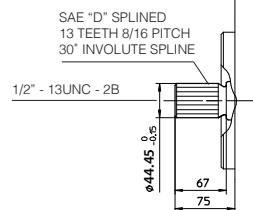

18 INSTALLATION DIMENSIONS OF OTHER CONTROLS

18.1 PVPC size 3, 4 and 5

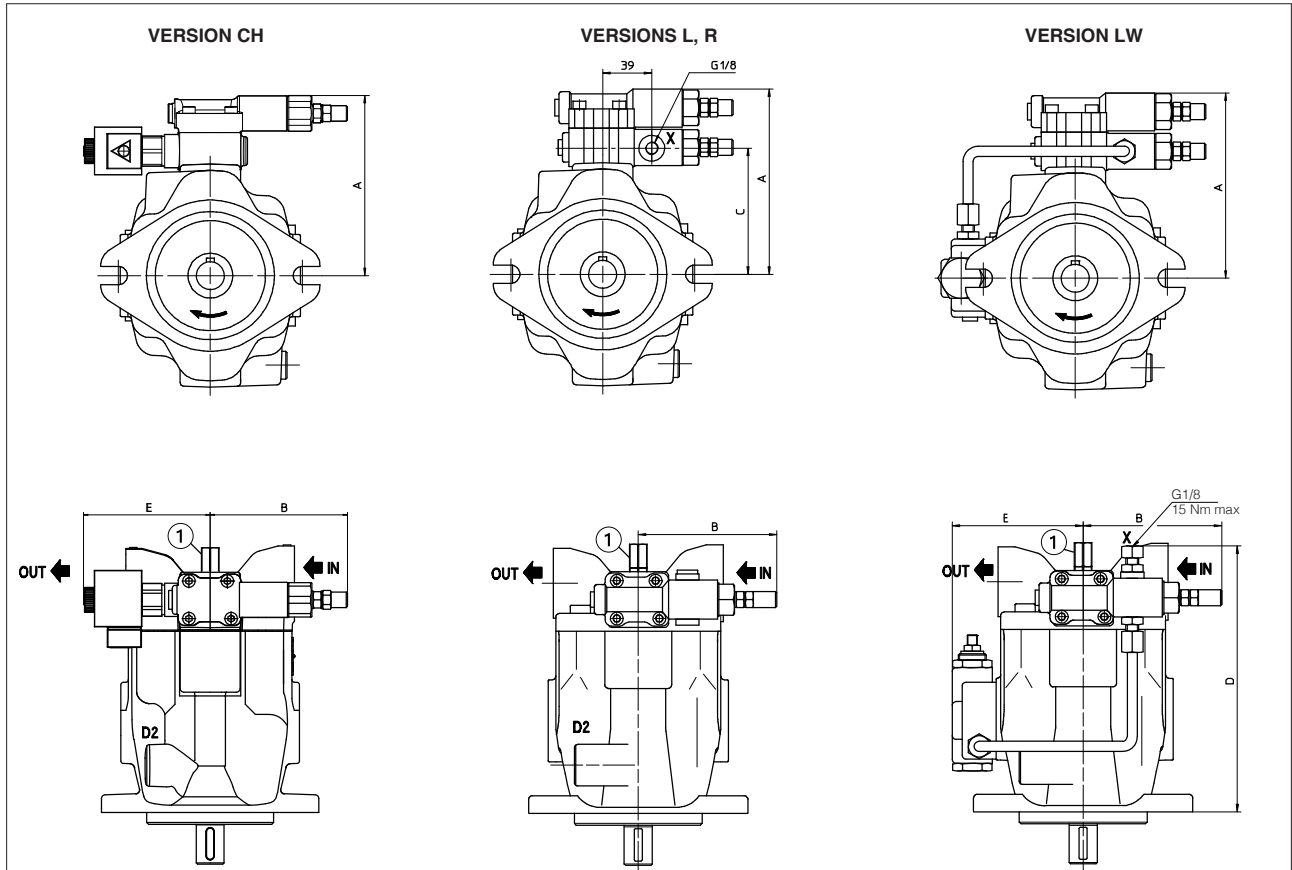

① = Regulation screw for max displacement. Adjustable range 50% to 100% of max displacement).
 In case of double pump the regulation screw is not always available, please contact our technical office.

Drawing shows pumps with clockwise rotation (option D): pumps with counterclockwise rotation (option S) will have inlet and outlet ports inverted and also the consequently position of the control groups

Pump type	Version	A	B	C	D	E	Mass (kg)
PVPC-*-3029	CH	144	111	-	-	102	22
	L-R	144	111	100	-	-	19,2
	LW	144	111	-	211	104	20
PVPC-*-4046	CH	153	111	-	-	102	28
	L-R	153	111	109	-	-	25,2
	LW	153	111	-	235	111	26
PVPC-*-5073 PVPC-*-5090	CH	166	111	-	-	102	36,9
	L-R	166	111	122	-	-	34,2
	LW	166	111	-	258	120	35

18.2 PVPC size 6

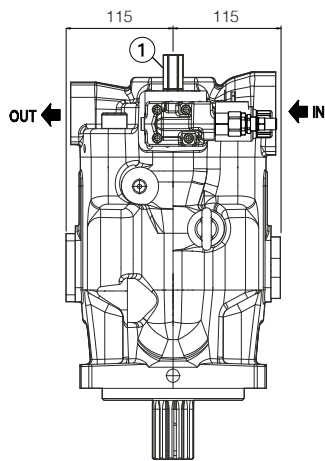
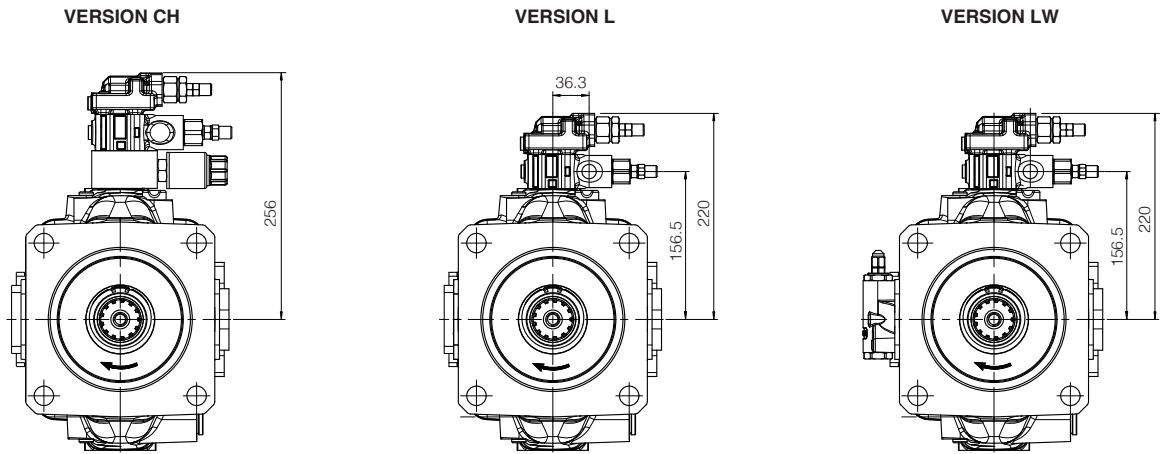

Mass [kg]	
PVPC-*-6140	74
PVPC-*-6160	

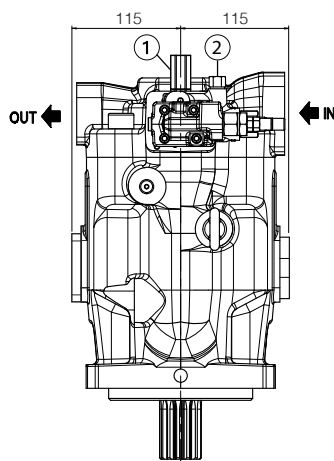

Mass [kg]	
PVPC-*-6140	70.2
PVPC-*-6160	

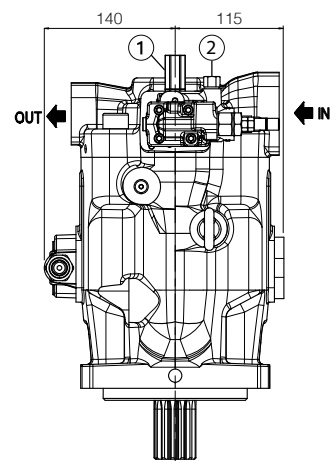

Mass [kg]	
PVPC-*-6140	71
PVPC-*-6160	

- ① = Regulation screw for max displacement. Adjustable range 50% to 100% of max displacement.
In case of double pump the regulation screw is not always available, please contact our technical office.
- ② = Load-sensing port G1/8" (tightening torque 15 Nm).

Drawing shows pumps with clockwise rotation (option D): pumps with counterclockwise rotation (option S) will have inlet and outlet ports inverted and also the consequently position of the control groups

19 RELATED DOCUMENTATION

- A900** Operating and maintenance information for pumps
- K800** Electric and electronic connectors